



Assessment of Three Alternating Pressure Sequences Applied to a Dynamic Cushion to Relieve Pressure on Seating Areas

S. Arias*
P. Rogeli*
E. Cardiel*
H. Sanada**
T. Mori**
H. Noguchi**
G. Nakagami**
L. Garay***

*CINVESTAV-IPN.

**The University of Tokyo

***Instituto Politécnico Nacional

ABSTRACT

Pressure ulcers are injuries to the skin and/or underlying tissues caused by prolonged high pressures on supporting body areas, they affect mainly people with poor mobility that have stayed in seating position for a long time. Reducing the amount and duration of pressure has been widely accepted for minimizing the risk of formation of pressure ulcers. Recently, dynamic cushions have been developed to relieve pressure on supporting areas; nevertheless, there is no sufficient information about the adequate characteristics of alternating sequences for pressure ulcers prevention. Therefore, the aim of this work is to explore three sequences of alternating movements designed for an air cell cushion by comparing pressure redistribution on supporting areas when applied on healthy volunteers. The purpose of these sequences is to redistribute the pressure over a larger contact area. To evaluate the effect of the alternating sequences, eight healthy volunteers were asked to sit on the air cell cushion, and to try the three alternating sequences for 12 minutes, 2 minutes on static mode and 10 minutes on alternating mode. A parameter for quantitative assessment of alternating sequences was proposed in this work by determining the coefficient of variation of interface pressure. Furthermore, the percentage of relative change of coefficient of variation was computed for evaluating performance of the alternating sequences comparing to the static mode. It was found that the three proposed strategies maintained values of interface pressure lower than previous work. Additionally, the relative change allowed to differentiate the effects of alternation of each sequence showing the second strategy as the most effective. The results are encouraging for further studies in subjects who require a wheelchair for mobility.

Keywords: pressure ulcers, dynamic cushion, strategy of control, pressure distribution, wheelchair cushion, alternating system, prevention.

Correspondencia:
Sandra Arias
Av. IPN 2508 Zacatenco 07360,
México DF
Correo electrónico:
sarias@cinvestav.mx

Fecha de recepción:
22 de mayo de 2014
Fecha de aceptación:
17 de octubre de 2014

RESUMEN

Las úlceras por presión son lesiones en la piel y tejidos subyacentes, causadas por presiones excesivas y prolongadas en las superficies de apoyo del cuerpo. Estas lesiones afectan principalmente a personas con poca movilidad física, como aquellas que permanecen sentados por largos periodos. Para disminuir el riesgo del padecimiento de estas lesiones, se ha recomendado como punto de partida reducir la magnitud y el tiempo de acción de las presiones en las zonas de apoyo. Se han desarrollado cojines dinámicos para sillas de ruedas, los cuales generan movimientos alternantes en las diferentes zonas de apoyo, producido por la inyección de aire, con el fin de disminuir las presiones en esas zonas. Sin embargo, no se han encontrado referencias acerca de las características adecuadas de las secuencias de movimientos alternantes para prevenir la aparición de esas lesiones. El propósito de este trabajo es evaluar tres secuencias de movimientos alternantes diseñadas para un cojín de aire. La evaluación se realizó comparando la distribución de presiones en zonas de apoyo antes y durante la aplicación de estas secuencias alternantes en personas sanas. Las secuencias propuestas se aplican para el inflado y desinflado de celdas que forman el cojín y fueron diseñadas con el objetivo de distribuir las presiones en un área mayor de apoyo. La prueba se realizó en 8 sujetos sanos, con un tiempo de estudio de 12 minutos para cada secuencia diseñada; 2 minutos en modo estático y 10 minutos en modo alternante. Se propuso determinar el coeficiente de variación para evaluar de forma cuantitativa el efecto de las secuencias alternantes sobre la presión de interfaz. Además se calculó el porcentaje de variación relativa del coeficiente de variabilidad entre los modos basal (estático) y alternante como una herramienta para evaluar el desempeño de las secuencias propuestas en relación a la presión de interfaz. Se encontró que las tres estrategias mantuvieron presiones de interfaz por debajo de los valores reportados en trabajos previos. El porcentaje de variación relativa permitió diferenciar el efecto de la alternancia de cada una de las secuencias propuestas, mostrando la segunda estrategia como la más efectiva. Los resultados obtenidos son alentadores para continuar el estudio en sujetos que requieren una silla de ruedas para su movilidad.

Palabras clave: úlceras por presión, cojines dinámicos, estrategias de control, distribución de presión, cojines para silla de ruedas, sistemas alternantes, prevención.

INTRODUCTION

Pressure ulcers are injuries caused by high pressure applied on the skin for a prolonged time [1]. They are usually located over a bony prominence and affect people with poor mobility that have maintained seating position for a long time[2]. Pressure ulcers are significant problem for wheelchair users due to the implications in health care cost and suffering[3].

Pressure ulcer prevention is focused on the reduction and the release of pressure over seating area[4][5]. For this reason, several types of wheelchair cushions have been developed for reducing the excessive pressure on a local region and redistributing the loads over a larger surface seating area[6]. Commercially available cushions include those made of foam, gel, a combination of foam and gel, static air cushions, as well as some prototypes as hydraulic cushions [7][8][9].

Being that even the best support surfaces do not redistribute pressure to a threshold below the risk of developing pressure ulcers[1], it has been suggested that relieving pressure by periodical intervals is a good strategy for preventing pressure ulcers[10][11]. Recently, some dynamic air cushions have been developed to relief pressure by alternating inflation and deflation over a period[12][13][14]. These cushions are very helpful when patient repositioning is not performed frequently[15]. These dynamic cushions relieve pressure over the seating area without the need of moving the patient[16].

Likewise, there has been increased interest in the study and improvement on the effectiveness of the alternating pressure for preventing pressure ulcers[17]. Nonetheless, consensus of the proper mechanical characteristics of the cushion and the alternating methods have not been established[18].

The purpose of this study is to explore three different alternating pressure sequences for pressure redistribution on the user contact area. These sequences were designed to avoid pressure concentration on a small area and were implemented on an air cell cushion described in the previous work[19]. Thus attempting to reduce the risk of formation of pressure ulcers on wheelchair users.

To evaluate the three alternating sequences, a comparison study was carried out among responses of the developed air-cell cushion, under with/without the alternating pressure sequences. A parameter to evaluate the magnitude of pressure alternation by using changes of coefficient of variation CV is proposed in this work.

METHODOLOGY

Developed Cushion

The cushion consists of 12 air cells interconnected in pairs thus resulting into 6 sections, 4 sections for covering buttocks area and 2 sections for thighs area. Each cell has a pressure sensor to measure inner pressure and all sections are individually inflated by 6 electro-

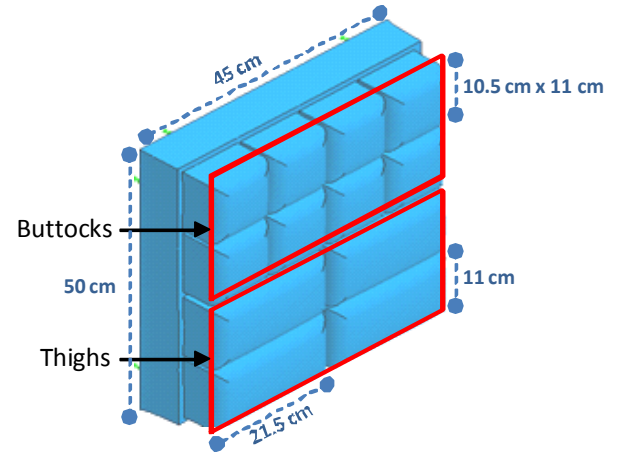

Figure 1. Model of the cushion with its divisions.

valves and deflated by other 6 electrovalves, controlled by a software developed in LabVIEW®. The cushion is made of vinyl with dimensions corresponding to an adult size cushion, the cushion sections can be observed in Figure 1. Further information of the description and calibration of this system was reported in a previous work [19].

Alternating Sequences

Three strategies of control of the air cell cushion were programmed.

- A) *Alternating strategy 1:* This sequence is based on the common strategies of dual commercial cushions[13] with a variant in the cycle characteristics of inflating and deflating sequence. This strategy is realized in four phases as shown in figure 2 where three sections of the cushion are inflated at a maximum inner pressure of 37 mmHg while the other three are deflated at a minimum inner pressure of 32 mmHg. It is continuously alternated over all the supporting area. Each cycle of 4 phases lasts about 30 seconds.
- B) *Alternating strategy 2:* The aim of this strategy is to generate a mechanical stimulation intended to promote blood flow by alternating pressure on the thighs and buttocks individually from the front to the back of supporting areas and vice versa [20]. This strategy consists of 4 steps that

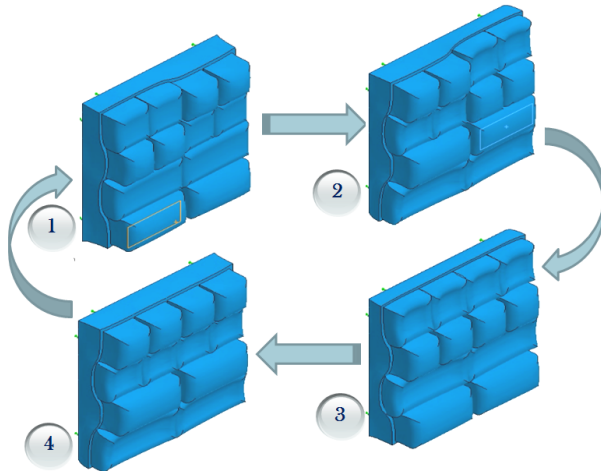

Figure 2. Sequence of the alternating method 1.

last about 2 minutes: the first step is to inflate all the air cells to a basal inner pressure of 32 mmHg, the second step is to increase the pressure under the area of the thighs up to 40 mmHg and after that release the pressure in this area down to 30 mmHg, and maintaining this low inner pressure until the next phase is achieved. Then in the third step, the gluteal area is stimulated by inflating and deflating the right and left sides in 5 phases from a minimum pressure of 30 mmHg to a maximum inner pressure of 40 mmHg. The final step is to release the inner pressure on the thighs and gluteal area at 27 mmHg, after that it makes a pause of 18 seconds and start the process all over again. This sequence induces pressure releasing in frontal and sagittal plane which are similar to the movements generated by healthy subjects during seating [21].

- C) *Random strategy*: The purpose of this strategy is to modify the pressure in the supporting areas all the time. This strategy involves three randomized parameters, the selection and number of cells and the inner pressure to be inflated or deflated. This strategy can reach a maximum inner pressure of 40 mmHg and a minimum inner pressure of 20 mmHg. The duration of each cycle depends of the time that the random parameters are reached.

Table 1. Subjects data.

Number of subjects	8
Female	5 (62.5 %)
Age(years)	31.5 ± 6.3 SD
Weight(kg)	60± 11.1 SD
Height(m)	1.64± 0.08 SD
BMI	22.06± 2.5 SD
< 18.5	1(12.5%)
18.6-25.0	7(87.5%)

BMI=Body Mass Index

Participants for the Study

Eight healthy volunteers, 5 females and 3 males, were recruited to participate in this study. Participants were between the ages of 23 to 43. A written consent was obtained from the volunteers before starting the measurements and the procedure was also fully explained to them. Further information about participant characteristics is provided in Table 1.

Protocol of Evaluation

Volunteers underwent three alternating strategies. For this purpose a standard wheelchair was used. Before starting each study, the cushion was inflated at 7 mmHg as baseline inner pressure without load by a developed algorithm in order to standardize our proposal of set up. At the beginning of the study, the volunteers were asked to sit straight on the cushion placed on the wheelchair and to place their feet on the footrest, while placing their back on the back of the chair with their hands resting on thighs. The hips, knees and ankles were flexed at 90°. Finally they were asked to try as much as possible not to move during the study. The study for each method was started at least one minute after static seating and lasted for 12 minutes, 2 minutes on static sitting and 10 minutes with the alternating method of the cushion.

Equipment to Evaluate Interface Pressure

In order to evaluate the changes on interface pressure on the sitting area after applying the proposed strategies, we used a pressure mapping system with a 1024 sensors (32 × 32) matrix with

a sensing area of 471.4 mm × 471.4 mm and a sample rate configured at 8 frames per second (CONFORMat, Nitta Co., Osaka Japan)[13]. The sensor mat was placed between the cushion and the participant. The system was calibrated according to the manufacturer’s instructions before starting the study.

Data Analysis

Variation of interface pressure

To evaluate the pressure redistribution during the application of alternating strategy, the entire map given by CONFORMat was divided into 8 sections, 4 sections on the right side and 4 sections on the left side, Figure 3. For each section, coefficient of variation (CV) of interface pressure was computed for 2 minutes on static sitting defined as ‘Baseline’ and the last 2 minute recordings during the 10 minutes of the alternating sequence. Coefficient of variation is the ratio between standard deviation SD to the Mean as shown in equation 1.

$$CV = \frac{SD}{Mean} \quad (1)$$

To compare among the strategies, the percentage of relative change of coefficient of variation for interface pressure was computed in every section of each strategy of control as shown in equation 2.

$$\%Relative\ Change = 100 \left(\frac{CV_{Alt} - CV_{stc}}{CV_{stc}} \right) \quad (2)$$



Figure 3. Sections of the sensor matrix for data analysis of interface pressure.

Where CV_{Alt} is the coefficient of variation of the alternating phase, and CV_{stc} is the coefficient of variation of the static phase or baseline. Positive values indicate that the coefficient of variation was higher on the alternating strategy, and negative values indicate that the static phase was higher compared with the alternating method. The highest increase of variation among the strategies indicates larger alternation of pressure on the seating areas.

Interface pressure parameters

In order to observe the pressure distribution during each alternating sequence, the user contact area was computed and grouped into 10 intervals of 20 mmHg each, from 0-200 mmHg. The contact area for each interval of pressure was computed from the average of the last two minutes of recordings of the study. Additionally, parameters commonly used for evaluating cushions[13][15] such as mean value, and peak pressure were computed from these recordings.

Statistical Analysis

A normal distribution test was performed with the Kolmogorov-Smirnov test for each coefficient of variation determined for all the sections, including both static and alternating modes. A paired t-student test was performed to detect differences among the coefficients of variation for each alternative strategy with the baseline pressure condition, which indicates a general performance. All differences with p-Values less than 0.05 were considered significant.

RESULTS AND DISCUSSION

Variation of interface pressure

In alternating strategy 1, there was no significant difference between the static mode and the alternating strategy. Figure 4 shows the changes in terms of coefficient of variation after the application of the alternating method. It suggests that there was no significant relief of interface pressure in the supporting area.

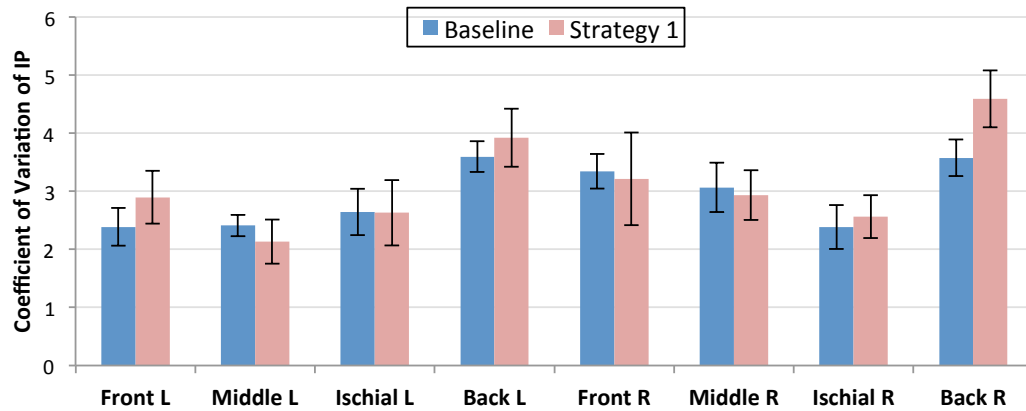

Figure 4. Coefficient of variation of Interface Pressure during static mode (baseline) and alternating mode (strategy 1).

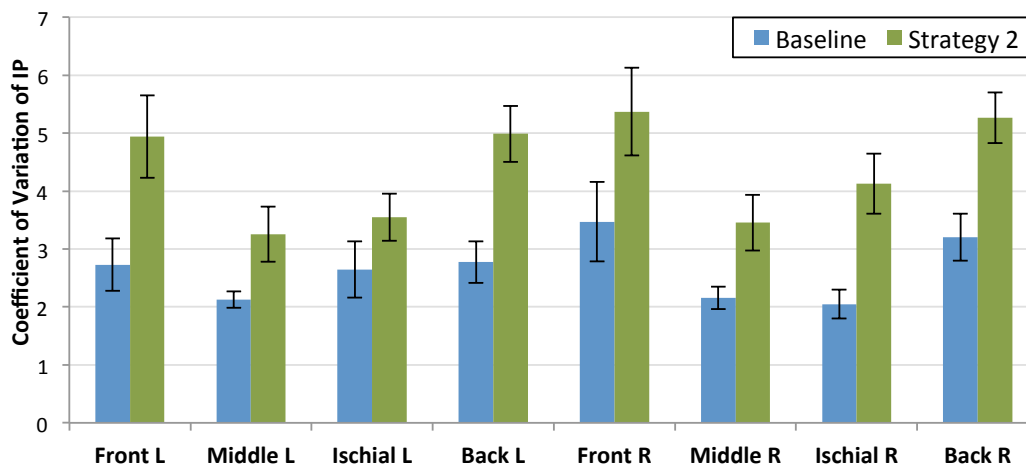

Figure 5. Coefficient of variation of Interface Pressure during static mode (baseline) and alternating mode (strategy 2).

In alternating strategy 2, there was significant difference in all the sections comparing the static mode and the alternating strategy. Figure 5 shows the comparison between the static mode and alternating strategy 2. There was clear increase on the variation after applying this method.

In the random strategy, 5 from 8 sections from interface pressure map showed significant differences. Figure 6 shows the changes of coefficient of variation between static mode and after applying the alternating method.

In figures 5 and 6, it can be observed that the CV in the Front and Back sections from the left and the right side increase more than the other sections. In addition, an increase of the contact area (Table 3) was obtained because

of the immersion of the body to the cushion. These conditions are associated with pressure redistribution.

The percentages of increasing of CV from the three alternating methods and the significant changes after applying the strategies are summarized in Table 2. Negative values observed in some sections suggest that there was a decrease of variation of interface pressure after applying the method. As observed in Table 2, alternating strategy 2 showed the greatest percentage of increasing of variation and also obtained the higher number of sections with significant differences between static and alternating modes which is the best response compared with the other alternating strategies.

Table 2. Percentage of relative change of coefficient of variation of Interface Pressure among the alternating strategies.

Section	Strategy 1		Strategy 2		Random	
	% Relative Change	Significant?	% Relative Change	Significant?	% Relative Change	Significant?
Front L	21.44 %	No p=0.31	80.95 %	Yes	75.0 %	Yes
Middle L	-11.62 %	No p=0.41	52.85 %	Yes	67.81 %	Yes
Ischial L	-0.38 %	No p=0.98	33.88 %	No p=0.11	-0.31 %	No p=0.99
Back L	9.04 %	No p=0.38	79.60 %	Yes	39.76 %	No p=0.08
Front R	-3.92 %	No p=0.43	54.76 %	Yes	57.71 %	Yes
Middle R	-4.28 %	No p=0.75	60.27 %	Yes	25.85 %	No p=0.15
Ischial R	7.56 %	No p=0.65	101.53 %	Yes	67.92 %	yes
Back R	28.35 %	No p=0.06	64.32 %	Yes	37.78 %	Yes

p-Value < 0.05 is considered as significant

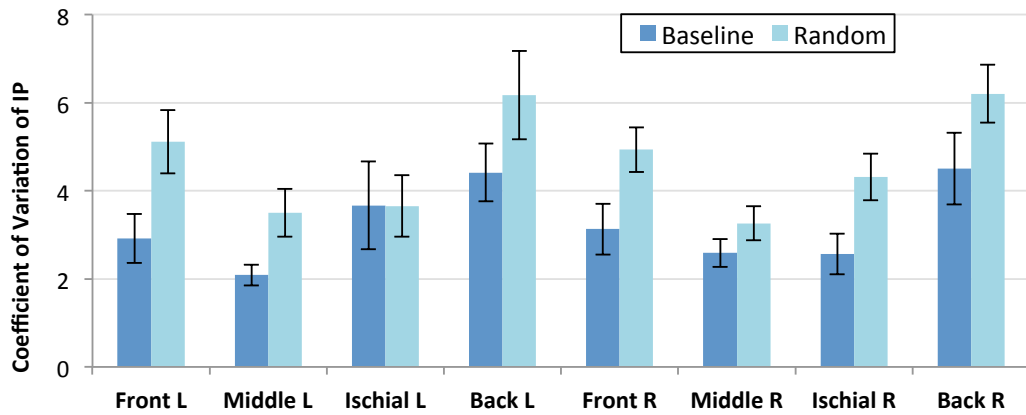

Figure 6. Coefficient of variation of Interface Pressure during static mode (baseline) and alternating mode (Random strategy).

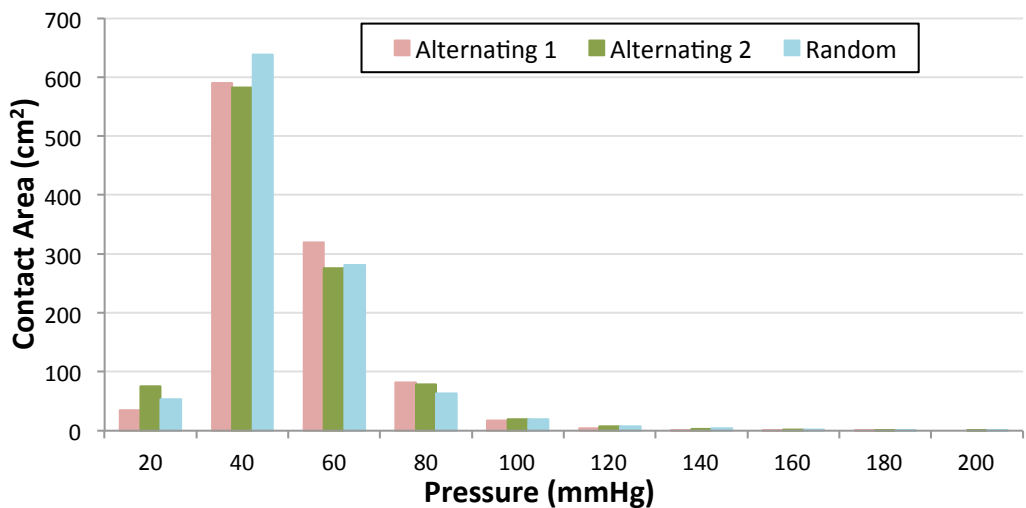

Figure 7. Total contact area for each interval of pressure.

Table 3. Comparison of parameters of interface pressure among the alternating strategies, each one from 2 minute recordings.

	Baseline	Alternating 1	Alternating 2	Random
Mean(mmHg)	40.73(0.31)	40.52 (5.31)	39.63 (6.56)	39.43 (6.72)
Peak(mmHg)	107(3.88)	103.30 (26.95)	114.57 (51.46)	113.09 (41.19)
TCS(cm ²)	917.59(2.23)	1062.1 (55.18)	1054.77 (59.96)	1081.02 (61.51)

TCS=Total Contact Area; Data are Mean(SD)

It might be because this strategy inflate and deflate the sections under the buttocks and thighs separately, which induce a widespread movement.

Interface pressure parameters

The pressure distribution, which corresponds to the user contact area for each interval, is observed in Figure 7. As observed, the highest concentration of pressure is in the interval of 20-40 mmHg for the three strategies, followed by the interval of 40-60 mmHg, which is favorable for pressure ulcers prevention [1]. Pressures lower than 120mmHg were obtained for the three strategies. The highest peak of pressure observed in this study corresponds to one sensor area of the entire matrix, which is not meaningful. Similar studies have reported histograms with interface pressure up to 180 mmHg [22].

The proposed alternating strategies showed similar results among them regarding interface pressure parameters, mean pressure, peak pressure and user contact area, at least within the last 2 minutes of sitting, as shown in Table 3. Usually, dynamic cushions may cause increase of peak values because of the reduction of contact area, but the results obtained in this work show that the proposed strategies did not cause these effects, which could be good for preventing pressure ulcers [13].

There are some studies for comparing mechanical behavior of different types of wheelchair cushions[7][15], but there is a lack of studies related to alternating sequences for dynamic cushions. The present study showed that the three proposed alternating sequences obtained similar values regarding to interface pressure parameters, these results were expected because the characteristics of the cushion did not

change with the alternating method. Moreover, coefficient of variation was very useful for assessing the alternating characteristics of the strategies proposed. An additional contribution of the presented alternating sequences is that these strategies continuously change the pressure by inflating and deflating the air cells at short time among cycles of alternation which provides a mechanical stimulation on sitting area that could promote stimulation of blood flow maintaining pressure redistribution. However, to assess this hypothesis, clinical studies should be done.

CONCLUSIONS

In the present study, we explored three alternating strategies for controlling a dynamic cushion. The three strategies showed favorable results related with interface pressure values. Additionally, we presented a method for determining coefficient of variation; this was very helpful for assessing the magnitude of alternation of the sequences, which indicates stimulation on sitting area. Regarding this parameter, alternating strategy 2 showed the best performance. The variation of pressure on the buttocks is important for preventing pressure ulcer.

Although, the results for healthy volunteers obtained on this study are encouraging, clinical studies are suggested to probe the effectiveness of the alternating strategies for dynamic cushion during a long period of time of sitting. Furthermore, given that pressure is not the only factor for pressure ulcer development, it is recommended that the cushion should be evaluated on studies that follow up skin conditions.

The random strategy presented in this work might affect the posture of the user; we recommend evaluation of posture in addition to the pressure measurement.

As observed, the good performance of a dynamic cushion does not only depend on the design of the cushion, but also on the method of distributing, relieving and alternating pressure on seating areas. With the alternating methods presented in this work, we attempt to create a dynamic cushion for preventing pressure ulcers on wheelchair users.

REFERENCES

1. International review, "Pressure ulcer prevention: pressure, shear, friction and microclimate in context", A consensus document. London: Wounds International, 2010.
2. Alam, M. Fitzpatrick's Dermatology in General Medicine. Archives of Dermatology, 2008, 140(3), 372-372
3. Bennett, Gerry, Carol Dealey, and John Posnett. "The cost of pressure ulcers in the UK". Age and ageing, 2004, 33(3): 230-235.
4. Hamanami, Kazunori, Akihiro Tokuhira, and Hajime Inoue. "Finding the optimal setting of inflated air pressure for a multi-cell air cushion for wheelchair patients with spinal cord injury". Acta Medica Okayama, 2004, 58(1): 37-44.
5. Sprigle, Stephen, Kao-Chi Chung, and Clifford E. Brubaker. "Reduction of sitting pressures with custom contoured cushions". J Rehabil Res Dev, 1990, 27(2): 135-140.
6. Apatsidis, Dimitrios P., Stephan E. Solomonidis, and Shona M. Michael. "Pressure distribution at the seating interface of custom-molded wheelchair seats: Effect of various materials". Archives of physical medicine and rehabilitation, 2002, 83(8): 1151-1156
7. Gil-Agudo, A., et al. "Comparative study of pressure distribution at the user-cushion interface with different cushions in a population with spinal cord injury". Clinical Biomechanics, 2009, 24(7): 558-563.
8. Stockton, Lesley, and Shyam Rithalia. "Pressure-reducing cushions: Perceptions of comfort from the wheelchair users' perspective using interface pressure, temperature and humidity measurements". Journal of tissue viability, 2009, 18(2): 28-35.
9. González, C. E., et al. "Asiento hidráulico con movimiento para prevenir úlceras por presión". Revista Mexicana de Ingeniería Biomédica, 2006, 27(1): 38-44.
10. Yih-Kuen, et al. "Wavelet-based spectrum analysis of sacral skin blood flow response to alternating pressure". Archives of physical medicine and rehabilitation, 2008, 89(1): 137-145.
11. Vanderwee, Katrien, Maria Grypdonck, and Tom Defloor. "Alternating pressure air mattresses as prevention for pressure ulcers: A literature review". International journal of nursing studies, 2008, 45(5): 784-801.
12. Attard, J., S. V. S. Rithalia, and J. Kulkarni. "Pressure relief characteristics in alternating pressure air cushions". Prosthetics and orthotics international, 1997, 21(3): 229-233.
13. Nakagami, Gojiro, Hiromi Sanada, and Junko Sugama. "Development and evaluation of a self-regulating alternating pressure air cushion". Disability and Rehabilitation: Assistive Technology (2013): 1-5.
14. McInnes, Elizabeth, et al. "Support surfaces for pressure ulcer prevention". Cochrane Database Syst Rev 4 (2011).
15. Ferrarin, Maurizio, Giuseppe Andreoni, and Antonio Pedotti. "Comparative biomechanical evaluation of different wheelchair seat cushions". Journal of rehabilitation research and development 2000, 37(3): 315-324.

16. McLeod, A. G. "Principles of alternating pressure surfaces". *Advances in Skin & Wound Care*, 1997, 10(7): 30-36.
17. Stockton, Lesley, and Shyam Rithalia. "Is dynamic seating a modality worth considering in the prevention of pressure ulcers?". *Journal of tissue viability*, 2008, 17(1): 15-21.
18. Clancy, Michael J. "Pressure redistribution devices: What works, at what cost and what's next?" *Journal of tissue viability*, 2013, 22(3): 57-62.
19. Arias, Sandra, et al. "A pressure distribution measurement system for supporting areas of wheelchair users". *Engineering in Medicine and Biology Society (EMBC), 2013 35th Annual International Conference of the IEEE. IEEE*, 2013.
20. S. Arias, E. Cardiel, P. Rogeli, T. Mori, H. Noguchi, G. Nakagami and H. Sanada, "An Alternating Pressure Sequence Proposal for an Air-Cell Cushion for Preventing Pressure Ulcers". *Engineering in Medicine and Biology Society (EMBC), 2014 36th Annual International Conference of the IEEE. IEEE*, 2014.
21. Reenalda, Jasper, et al. "Analysis of healthy sitting behavior: interface pressure distribution and subcutaneous tissue oxygenation". *Journal of Rehabilitation Research & Development*, 2009, 46(5): 577-586.
22. Bar, C. A. "Evaluation of cushions using dynamic pressure measurement". *Prosthetics and Orthotics International*, 1991, 15(3): 232-240.